

Typical Anemometer Support Booms

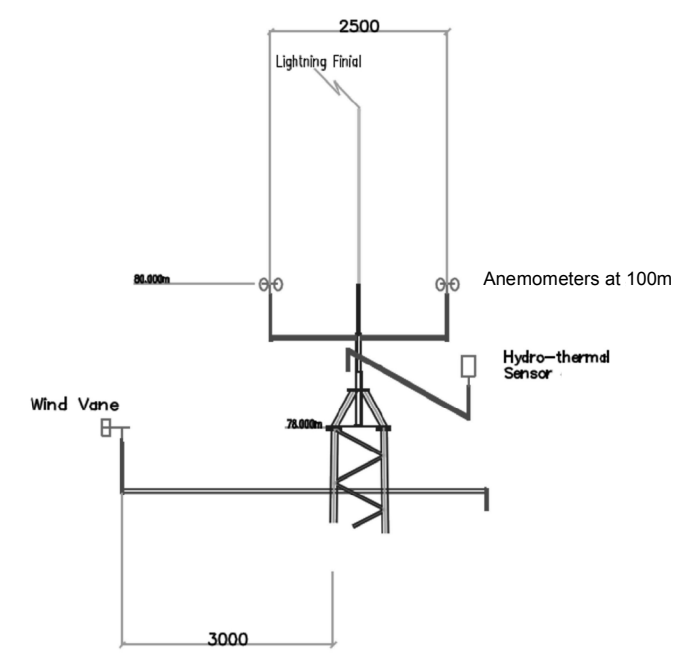

Tower Peak, Sliding Pole and Typical Booms

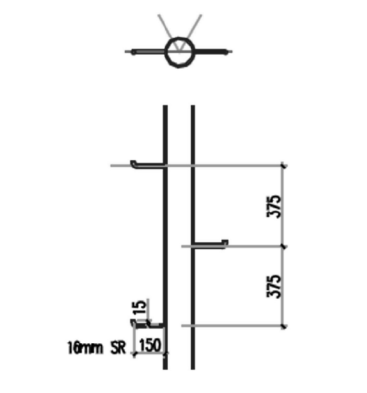
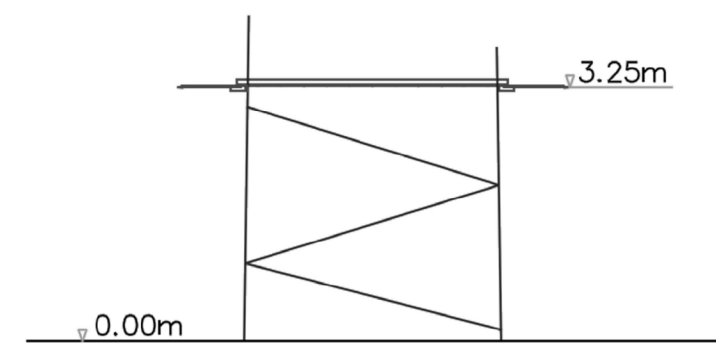

Climbing Step Bolts on one leg

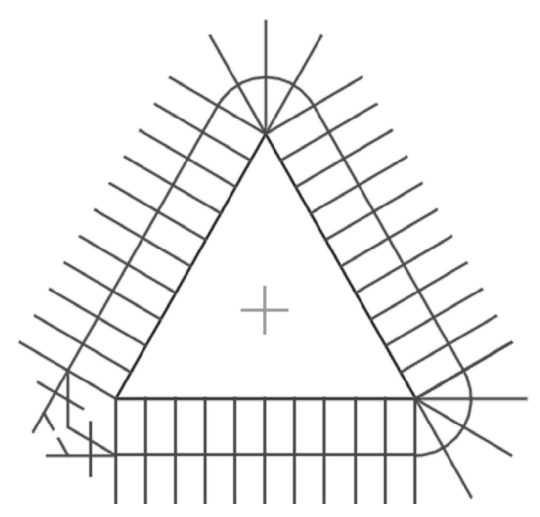

Note:  
 The tower is triangular lattice construction with hollow circular sections throughout.  
 A lightning finial would be fitted to the tower top and each leg of the tower should be connected to an adequate earth system.  
 Do not scale this drawing.